

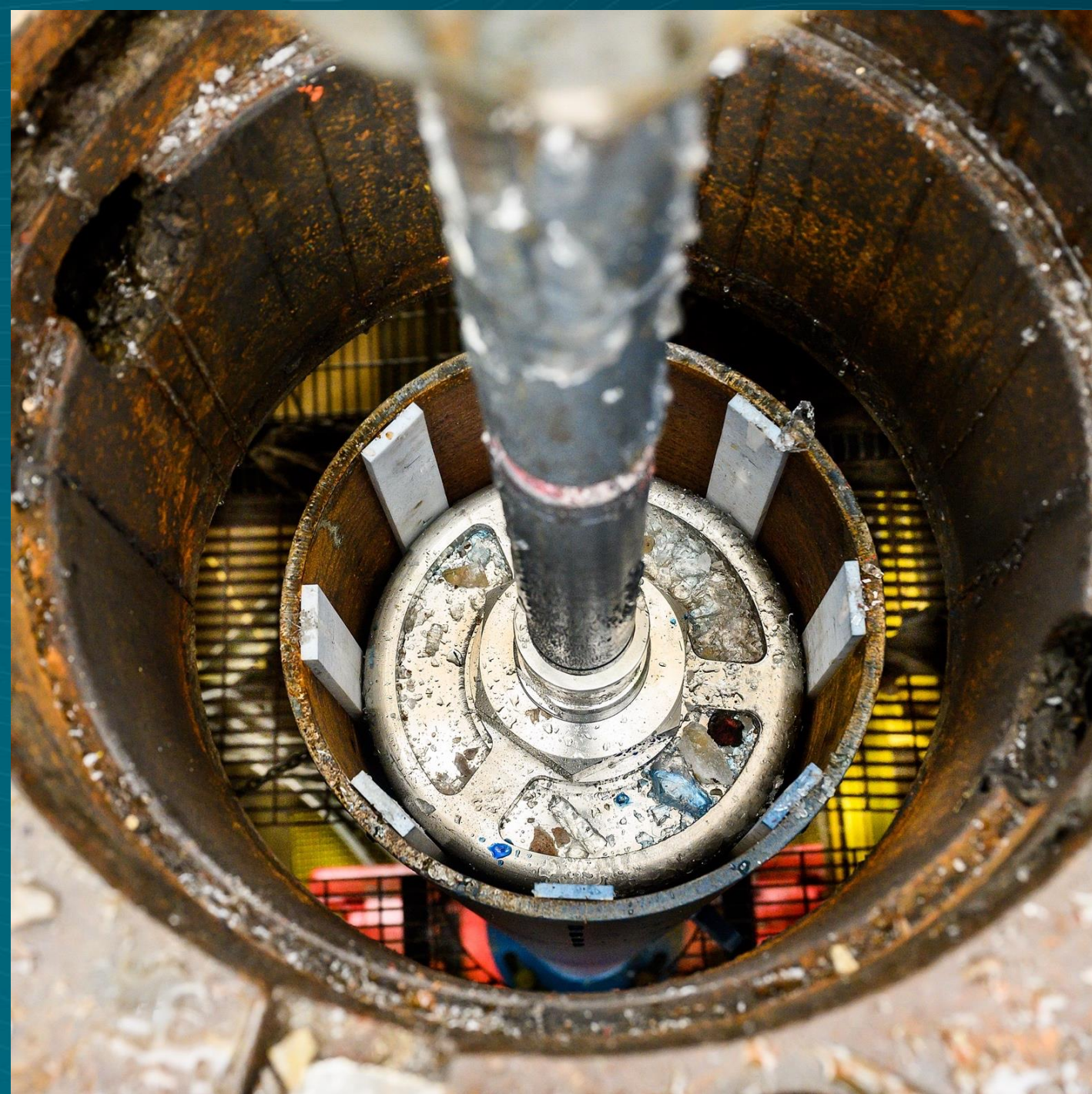

Deep Isolation Investor Presentation

April 2026



CERTAIN DISCLOSURES & DISCLAIMERS

This presentation includes forward-looking statements within the meaning of Section 27A of the Securities Act and Section 21E of the Exchange Act. Forward-looking statements relate to, among others, our plans, objectives and expectations for our business, operations and financial performance and condition, and can be identified by terminology such as “may,” “should,” “expect,” “intend,” “plan,” “anticipate,” “believe,” “estimate,” “predict,” “will,” “could,” “project,” “target,” “potential,” “continue” and similar expressions that do not relate solely to historical matters or actual results. Forward-looking statements are based on management’s belief and assumptions and on information currently available to management. Although we believe that the expectations reflected in forward-looking statements are reasonable, such statements involve known and unknown risks, uncertainties and other factors that may cause our actual results, performance or achievements to be materially different from any future results, performance or achievements expressed or implied by forward-looking statements. The forward-looking statements are subject to risks which include, but are not limited to, the risk factors included under the caption “Risk Factors” in the Company’s Current Report on Form 8-K, filed with the Securities and Exchange Commission on July 28, 2025.

Moreover, we operate in a highly regulated environment. New risks emerge from time to time. It is not possible for our management to predict all risks, nor can we assess the impact of all factors on our business or the extent to which any factor, or combination of factors, may cause our actual results to differ materially from those anticipated or implied in any forward-looking statements we may make. In light of these risks, uncertainties, and assumptions, the future events and trends discussed in this presentation may not occur and our actual results could differ materially and adversely from those anticipated or implied in the forward-looking statements.

You should not rely upon forward-looking statements as predictions of future events. The events and circumstances reflected in the forward-looking statements may not be achieved or occur. Although we believe that the expectations reflected in the forward-looking statements are reasonable, we cannot guarantee future results, performance, or achievements. We undertake no obligation to update any of these forward-looking statements for any reason after the date of this presentation or to conform these statements to actual results or revised expectations, except as required by law.

INTRODUCTION TO DEEP ISOLATION

Deep Isolation is a leading innovator poised to disrupt and dominate the market for nuclear waste storage and disposal



EXPERIENCE

Leading innovator of nuclear waste solutions with unique know-how

- Co-founded in 2016 by a father-daughter team of prominent scientists with previously successful co-founded ventures
- Leadership team has a combined 100+ years of direct experience with nuclear solutions and engineering, government and community engagement and global strategy development
- 18-member Advisory Board including preeminent experts in nuclear science, technology and policy as well as major business leaders and entrepreneurs in the sector
- Acquired Freestone Environmental Services in 2021, a successful and reputable small business involved in nuclear waste site clean-up



COLLABORATION

Recognition and collaboration with all major stakeholders

- Strategic collaboration in place with leaders in the nuclear services, drilling, manufacturing and engineering fields
- Collaborating with Halliburton on the world's first nonradioactive, full-scale at depth demonstration for borehole disposal
- Proven demand for deep geologic disposal supported by 18 feasibility and demonstration contracts signed to date across the globe
- Hands-on support from U.S. government domestically and in international markets
- Nuclear industry leader NAC International led Series A raise
- Focus on community engagement to garner public support for the Deep Isolation solution



QUALITY

Unique, proven solution with a massive competitive moat

- Flexible solution allows for temporary or permanent disposal options
- Boreholes drilled on site or near the plants, eliminating transportation risk and cost
- Proprietary corrosion-resistant universal canister design.
- 99 U.S. or international patents with 39 more in development covering vertical, slanted and horizontal borehole solutions⁽¹⁾
- No private sector direct competitors for deep geologic disposal
- Successfully demonstrated emplacement and retrieval of full-sized canister during initial testing in February 2023
- No debt on balance sheet



CULTURE

Close-knit team of experienced industry veterans

- Women-founded and led (former CEO and current Board Chairwoman)
- 45+ employees⁽²⁾ with average industry tenure of 20+ years
- Entrepreneurial, collaborative culture with flat structure and low turnover
- Mission-driven business directly involved in the advancement of new nuclear generation and the global energy transition
- Global reach and near around-the-clock availability with majority of employees located in the U.S. and one employee located in Europe

1) As of April 2026

2) Includes employees of Freestone Environmental Services, which is a 100% owned subsidiary of Deep Isolation.

COMPANY HIGHLIGHTS



1

Safest, Simplest and Most Cost-Effective Solution to the Nuclear Waste Problem

- Global academic and policy consensus that deep geological disposal is the safest solution for permanent disposal of high-level nuclear waste
- Deep borehole disposal represents a 70% cost saving compared to today's "solutions": mined repositories and temporary storage
- Deep Isolation employs mature, proven technologies and is the only permanent disposal solution ready for near-term deployment

2

\$300 Billion Total Addressable Market Opportunity by 2050 "Up for Grabs"

- Estimated ~\$155B addressable market based on today's waste inventory, projected to grow to ~\$300B by 2050 as global nuclear capacity expands
- Outside of Finland, Sweden and France, no other country has made material progress toward a permanent disposal solution for waste
- Deep Isolation's proprietary universal canister system can also be deployed for interim waste storage opportunities

3

Patent-Protected and Scalable Business Model

- Extensive portfolio of IP covering every aspect of deep borehole disposal, presenting formidable barriers to entry
- No identified private sector direct competitors for the Company's solution
- Global partnerships with leading drillers and nuclear waste management companies ensure seamless end-to-end delivery

4

Active U.S. Federal Support and Advocacy, Domestically and Abroad

- Multiple grants, totaling ~\$6 million awarded from U.S. Department of Energy
- Secured formal Advocacy assistance from U.S. Government in the Philippines, with other Advocacy applications in process
- Paid support from U.S. State Department to execute consultancy studies with 6 countries in Eastern Europe

5

Strong Financial Profile with Substantial Long-Term Growth Potential

- Well-managed, low overhead business, with revenue projected to grow to ~\$140M by 2030, ~\$450M by 2035 and \$2.2B by 2040
- Asset-light business model offers opportunity to invest directly in the global energy transition with minimal ongoing capital expenditure
- Global licensing opportunity with strategic partners and governments unlocks significant passive revenue potential

6

Experienced Leadership Team Supported by a World-Class Advisory Board

- Decades of combined C-suite, government and NGO leadership experience specific to the nuclear sector
- Impressive Advisory Board including nuclear technology and policy leaders, and successful entrepreneurs
- Innovative and entrepreneurial culture with the sole focus of revolutionizing the nuclear waste management sector

OUR HISTORY AND GROWTH

2019

\$9.3M seed round is oversubscribed

Deep Isolation becomes the first company to **successfully place and retrieve a prototype disposal canister** from a deep horizontal borehole in a public demonstration

Deep Isolation signs **cooperative MOAs with Bechtel and NAC International**



2021

Dominion Engineering partnership announced



Contract awarded with ARAO to study feasibility of DBD in Slovenia



Acquisition of **Freestone Environmental Services**



Feasibility study commissioned from **ERDO Working Group** (Croatia, Denmark, Netherlands, Norway, Slovenia)



2023

£611k grant awarded for canister development in UK



Deep Borehole Demonstration Center is launched with Deep Isolation's support



Mentor-Protégé arrangement signed with **SIMCO** at Waste Isolation Pilot Plant



ARPA-E & DOE contract awarded



MOU signed with Curio to study disposal of high-level waste from recycling



2025

Deep Isolation completes Alternative Public Offering (APO) and oversubscribed \$30 million financing



2026

Deep Isolation launches **full-scale demonstration program** for nuclear waste disposal at Deep Borehole Demonstration Center facility in Cameron, TX



2016-2018

Deep Isolation is **founded in 2016** in Berkeley, CA by the father-daughter team of Richard and Liz Muller

Significant **research and technical due diligence** conducted to support the feasibility of deep borehole disposal

\$600k angel round is oversubscribed

Deep Isolation's **first patent** is issued in the U.S.

Rod Baltzer is hired, and Deep Isolation **emerges from stealth mode**

2020

NAC International leads **\$20M Series A raise**⁽¹⁾ and signs long-term cooperation and licensing agreement for canisters



First customer contract signed with **EPRI** for feasibility report



Geological readiness **contract signed with Fermi Energia** in Estonia



Expansion to UK to better serve the EMEA market, with **NDA as first client**



Deep Isolation releases preliminary **radiological safety calculations**

2022

Two ARPA-E contracts awarded totaling **\$4.1M** in partnership with Oklo, Argonne National Lab, Idaho National Laboratory, Lawrence Berkeley National Lab and NAC for advanced fuel disposal and canister design



Licensing partnership announced with **Amentum**



Two grants awarded from DOE in partnership with **EPRI** and **Argonne**



Further partnership announced with **Fermi Energia** in Estonia



2024

Signed MOU with **SHINE Technologies**



Delivers **first prototype canister** in partnership with UK government



Strategic partnership announced with **Navarro Engineering**



DOE award in collaboration with **Kairos Power** for the study of TRISO fuel disposal



Contracted by IAEA to undertake regulatory gap analysis for DBD



Appointed by U.S. Department of State to provide paid support on waste management to governments in Central and Eastern Europe



1) \$20 million amount includes conversion of seed and angel rounds.

OUR LEADERSHIP TEAM

Highly experienced team with unmatched, complementary expertise and a long history together



Rod Baltzer

Chief Executive Officer

- Joined Deep Isolation in 2018
- 25 years of experience in the nuclear waste industry, including radioactive waste licensing and disposal, stakeholder engagement and management
- Previously served as CFO, President and CEO for Waste Control Specialists over 14 years
- B.S. in Agricultural Economics & Accounting from Oklahoma State University



Joseph Nelson

Chief Financial Officer

- Joined Deep Isolation in 2026
- Over 20 years experience in financial leadership, fundraising, M&A and driving corporate growth in the energy sector
- Previously served as CFO of Delta Corp. Holdings Limited, and public companies GasLog Ltd. and GasLog Partners LP
- M.B.A., with finance specialization from NYU Stern School of Business



Chris Parker

Chief Commercialization Officer

- Joined Deep Isolation in 2020
- 34 years of experience in stakeholder engagement, governance and partnership development Formerly a senior civil servant reporting directly to the British Prime Minister on the digital transformation of UK's economy and public services
- M.B.A with distinction from Imperial College London and B.A. in French and International Studies from University of Warwick



Paula Whitten-Doolin

General Counsel

- Joined Deep Isolation in 2026
- Over 15 years experience in corporate and legal affairs in the energy industry
- Previously served in senior legal roles, including as General Counsel, with Houston First Corp., Ideanomics, Neste, SLB and MI SWACO
- B.S. from California Institute of Technology; J.D. from Northwestern University School of Law



Sophie McCallum

Chief of Staff

- Joined Deep Isolation in 2018
- 14 years of experience in growing and scaling early stage companies, fostering collaboration and implementing systems
- Previously served as Director of Operations at ClinCapture and in equity derivatives roles at BNP Paribas
- M.B.A in Entrepreneurial Studies and International Studies from ESCP Business School



Jesse Sloane

EVP of Engineering

- Joined Deep Isolation in 2022
- 16 years experience in SNF and waste management, fabrication and transportation, risk engineering and management of large-scale nuclear, capital, and construction projects
- Former U.S. Naval Officer and lead engineer of Spent Fuel Disposal Projects of the Naval Nuclear Propulsion Program
- M.S. Nuclear Engineering from Penn State University; B.S. Mechanical Engineering and Mechanics from Drexel University



Steve Airhart

President of Freestone Environmental Services

- Co-owner of Freestone since 2004 and President since 2019
- 39 years of experience as a geologist specializing in environmental investigations, compliance, spill response and cleanup actions
- Has performed complex investigations for the U.S. DOD and U.S. DOE's Hanford Site
- Experienced Program Manager for large federal IDIQ contracts
- B.A. in Geology from University of Montana

OUR BOARD OF DIRECTORS

Highly accomplished board with decades of experience leading companies



Elizabeth Muller

Chair and Co-Founder

- Co-Founded Deep Isolation in 2016
- Currently serves as Board Chair



Rod Baltzer

Executive Director and
Chief Executive Officer

- Joined Deep Isolation in 2018
- Currently serves Chief Executive Officer



Leslie Tepper

Lead Independent Director
The Artemis Fund

- Joined Deep Isolation Board of Directors in 2019
- Committee Memberships:
 - Compensation (Chair)
 - Audit
 - Nominating & Governance



Renee Hornbaker

Independent Director
Stream Energy

- Joined Deep Isolation Board of Directors in 2025
- Committee Memberships:
 - Nominating & Governance (Chair)
 - Audit
 - Compensation



Jonathan Angell

Independent Director
Angell Investments

- Joined Deep Isolation Board of Directors in 2019
- Committee Memberships:
 - Audit (Chair)
 - Nominating & Governance



Christa Steele

Independent Director
Mechanics Bank

- Joined Deep Isolation Board of Directors in 2025
- Committee Memberships:
 - Audit
 - Compensation



Ralph L. Hunter

Independent Director
RC Nuclear Consultants

- Joined Deep Isolation Board of Directors in 2026
- Committee Memberships:
 - Compensation
 - Nominating & Governance

OUR UNPARALLELED ADVISORY BOARD

Exemplary Advisory Board includes top minds in geology, nuclear and environmental science alongside business leaders, innovators and entrepreneurs

	Meghan Caiazzo	Chief Commercial Officer at Prepared Hero and Co-founded Victory Wine Group
	Steven Chu	Nobel Prize winner in Physics; Former U.S. Secretary of Energy and Director of LBNL; creator of the Blue Ribbon Commission on America's Nuclear Future and ARPA-E
	Clay Collier	Expert in communication architecture and software development as well as a mentor at SkyDeck Berkeley
	Terry Considine	Real estate entrepreneur and investor serving as CEO for four REITs; current director of the Lynde and Harry Bradley Foundation in WI and Intrepid Potash in CO
	Bill Edwards	Managing Partner at CS Transformation and previously was the Chief Strategy Officer at Deep Isolation
	Richard Esposito	Current R&D Program Manager at Southern Company; President of the Alabama Geological Society
	Tom Isaacs	National and international leader in the fields of nuclear energy, nuclear waste management, nuclear security, controversial facility siting, stakeholder engagement, and earning public trust and confidence.
	Jeffrey Merrifield	Partner at Pillsbury Winthrop Shaw Pittman and former U.S. NRC commissioner
	Daniel Metlay	Former member of the Senior Professional Staff of the U.S. Nuclear Waste Technical Review Board and served in the Carter White House on radioactive-waste management

	Monica Mwanje	Provides strategic consultancy services for organizations seeking growth in nuclear and other regulated sectors
	Per Peterson	CNO of Kairos; Nuclear Engineering Professor at UC Berkeley focusing on high-temperature reactors, high-level nuclear waste processing and nuclear material management
	John Raymond	Nuclear sector entrepreneur, founder and former President of Kurion Inc.; recognized for innovation on waste management products
	Jen Schneider	Current Professor at Boise State University conducting research focusing on energy industry rhetoric and technical discourse; stakeholder engagement specialist
	James Smalhout	Former Federal Reserve economist, World Bank consultant, derivatives trader and author of over 100 financial publications
	Matthew Sunseri	Seasoned nuclear energy executive bringing deep expertise in nuclear safety, regulatory engagement, organizational performance, and enterprise risk management
	Barbara Laffin Treat	President & CEO of InfrastructureWorld and former Principal Vice President at Bechtel Corporation
	Rob Utter	Consultant at New Ventures Energy Consulting and has over 30 years of experience in drilling operations at Schlumberger
	Heather Westra	Independent consultant with over 30 years of experience in Indian Country focusing nuclear regulation

The State of Nuclear Waste Disposal

GLOBAL DEMAND FOR CLEAN, RELIABLE BASELOAD POWER IS GROWING...



Load forecasts are growing worldwide

Increased global power demand driven by electrification, deglobalization, industrial onshoring and data centers has materially increased long-term load forecasts



Grid reliability is a major concern

Due to climate concerns, global coal-fired generation is expected to decrease by ~5x through 2050 per IEA projections. As the grid is “greened up” with renewables, the increase in intermittent energy will continue to exacerbate grid reliability concerns



Decarbonization is at the forefront of the global energy sector

Climate change has become a leading policy issue globally, leading to net zero emission goals, pledges and/or mandates by the vast majority of countries and large corporations worldwide



Resilient power generation sources are in high demand

As extreme weather events have accelerated significantly over the last few decades, increased power outages and power price spikes have highlighted the need for a more resilient grid



Energy security is increasingly a focus in today's geopolitical climate

Recent geopolitical events, including Russia's invasion of Ukraine and escalating tensions between the U.S. and China, have highlighted vulnerabilities in global energy supply chain and the strategic importance of energy autonomy

Sources: EIA, McKinsey, IEA, Net Zero Tracker, EM-DAT, CRED / UCLouvain, St. Louis FRED.

1) Represents countries or corporations with proposed, pledged, in policy, in law or achieved net zero goals.

2) Based on the 2,000 largest publicly-traded companies in the world by revenue.

3) Represents the average spot WTI and Brent crude oil prices.

GLOBAL ENERGY CONSUMPTION ('000s of TWh)

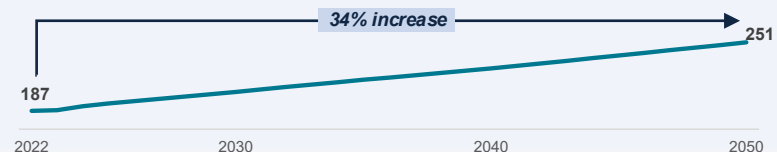

GLOBAL COAL GENERATION ('000s of TWh)

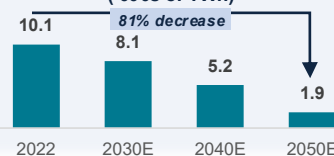

RENEWABLES' SHARE OF TOTAL GLOBAL GENERATION

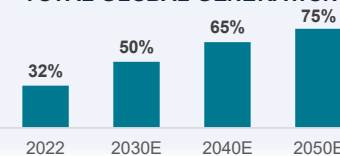

GLOBAL NET ZERO COMMITMENT⁽¹⁾



NUMBER OF GLOBAL NATURAL DISASTER EVENTS

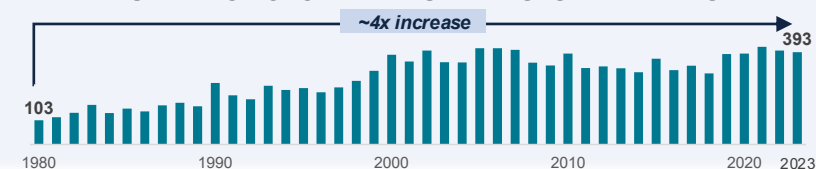

GLOBAL NATURAL GAS AND CRUDE OIL PRICES

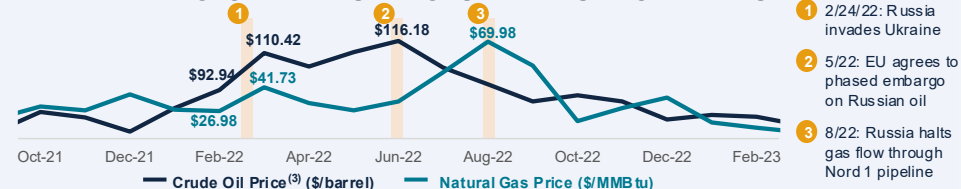

...ALONGSIDE WIDESPREAD RECOGNITION THAT NEW NUCLEAR POWER IS A CRITICAL PART OF THE SOLUTION

An increasing number of countries around the world recognize the critical role of nuclear energy for ensuring energy security and achieving net zero goals

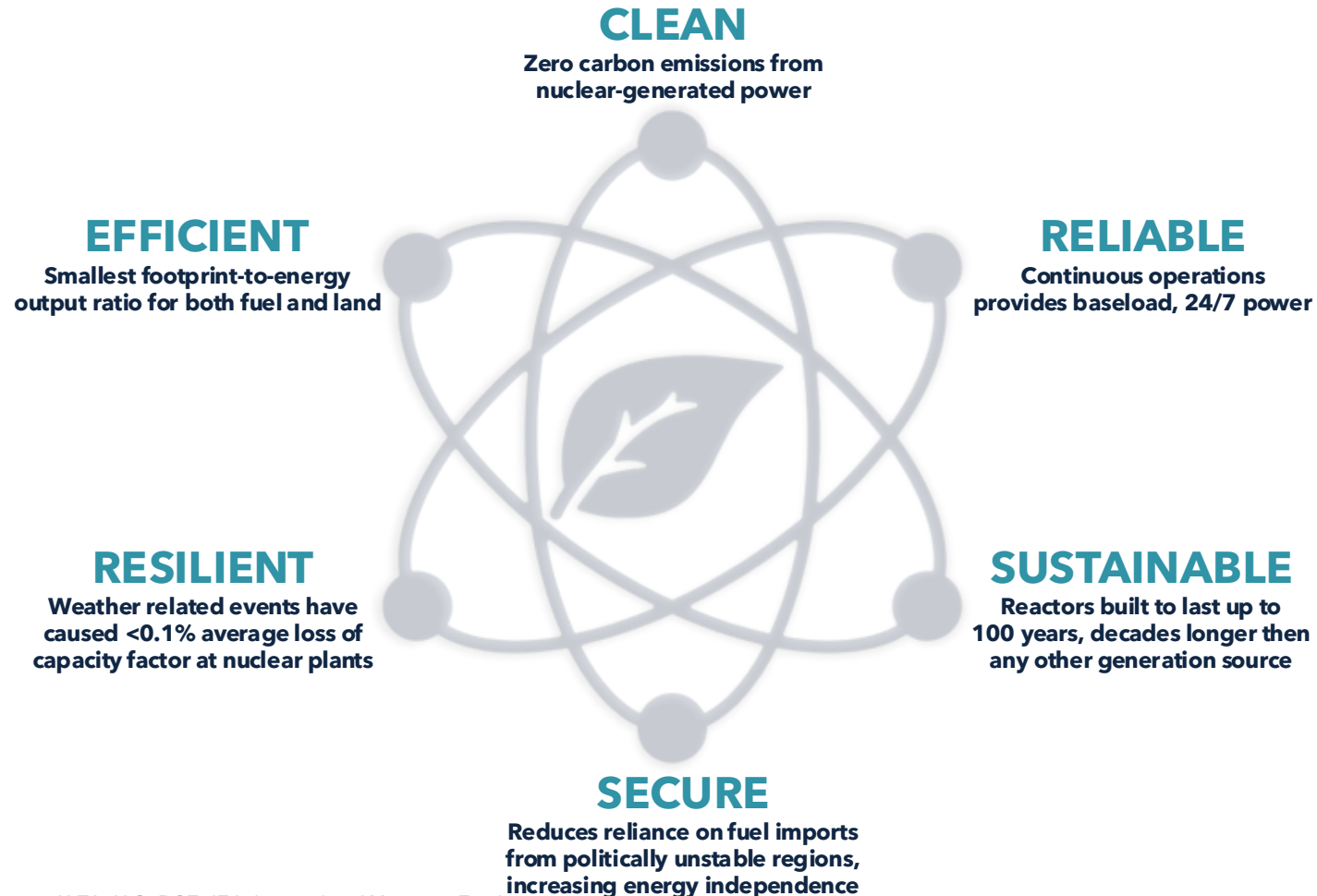

Sources: IAEA, U.S. DOE, IEA, International Monetary Fund.

1) Estimate from IEA's "Nuclear Power and Secure Energy Transitions" report.

2) Based on midpoint of IAEA's low and high cases. The U.S. DOE alone has a goal to add 200 GW of nuclear in the U.S. by 2050.

3x
25 countries (representing 41% of world GDP) pledged to 3x global nuclear capacity by 2050 at COP28



>\$2Tn
Annual global nuclear investment through 2050 needed to achieve global net zero by 2050⁽¹⁾

iea

300+ GW
Forecasted global increase in nuclear capacity through 2050⁽²⁾



A REALISTIC SOLUTION FOR PERMANENT WASTE DISPOSAL IS FUNDAMENTAL TO THE ROLLOUT OF NEW NUCLEAR

The world has not yet permanently disposed *any* of the spent fuel it has created over the last seventy years

Estimated Size of Existing Spent Fuel Inventories (MTHM)

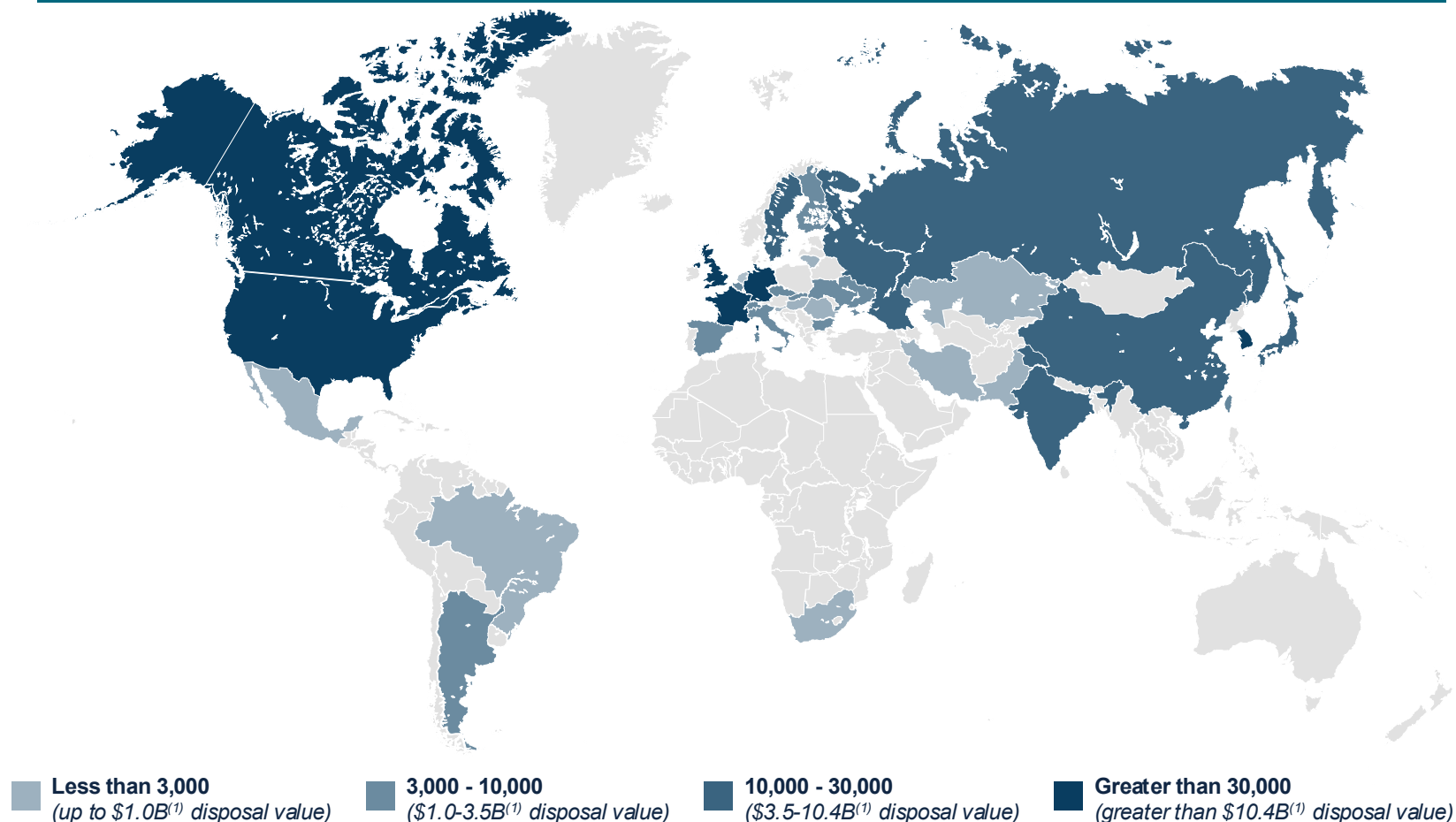

Sources: IAEA, Deep Isolation Financial Model.

1) Estimates the potential disposal value to Deep Isolation, assuming a weighted average cost of disposal of \$348k/MTHM based on \$424k/MTHM and \$170k/MTHM for unprocessed and reprocessed waste, respectively, per the Deep Isolation Financial Model. Assumes 30% of global waste is reprocessed, while remaining 70% is unprocessed. See the section titled "Risk Factors" in the Company's Form 8-K, filed with the SEC on July 28, 2025.

“

“To move the next generation of nuclear reactors forward, the industry needs to be able to tell investors and the government that we have a solution to the waste.”

– Rod McCullum
Senior Director, Used Fuel and Decommissioning at Nuclear Energy Institute

“

“...This issue has to be resolved. The communities that raised their hand to put nuclear facilities in their geographic boundaries did not raise their hand to store permanently, the spent nuclear fuel, and we are seeking to get a solution to that sooner rather than later.”

– Jennifer Granholm
Former U.S. Secretary of Energy

THE CURRENT NUCLEAR DISPOSAL APPROACH IS NOT WORKING

The world's current nuclear waste management model is nearly unanimously unpopular, resulting in the continuous cycle of delays in permanent disposal and indefinitely recurring storage costs

Mined Repository: *the expensive and unpopular option*

How does it work?

- Involves the mining of **miles of underground tunnels** to create a centralized repository in which all SNF produced by a certain country will ultimately be packed into canisters and emplaced
- Facility maintained by a **large staff** of engineers and other personnel **onsite and underground**

What does it cost?

- Construction can cost **billions to tens of billions alone plus significant operating and monitoring costs**, with a large staff on hand for decades
- In many cases where not all SNF is produced near the disposal site, countries will also incur **significant transportation costs**

How long does it take to deploy?

- Projects take **decades to plan and deliver** before becoming operational
- **Political opposition can cause decades of delays** – *in the U.S., Yucca Mountain was selected as the site for all U.S. SNF disposal in 1987, but has made no material progress to date*

What progress has been made to date?

- There are **no currently operating mined repository facilities for the disposal of SNF**
 - Finland is on track to open the world's first SNF disposal facility in 2025
 - Sweden and France are next in line, and neither country has begun construction
- Only a **handful of countries** have made significant progress in even **selecting a site**

Why is this option so unpopular?

- **Community Opposition** – most citizens are deeply opposed to living near a nuclear waste site
- **Cost** – most expensive solution for SNF disposal *plus* many more years of interim storage costs
- **Safety** – requires transportation of radioactive waste over long distances; requires constant human intervention underground

Above-Ground Interim Storage: *the “kick-the-can” option*

How does it work?

- Involves packaging SNF into canisters that are then placed and **stored in above-ground concrete dry casks** located onsite at the power plant where the SNF was produced
- **Onsite monitoring and maintenance required**

What does it cost?

- **Globally, the annual spend for temporary storage of SNF is ~\$10B**– the U.S. alone spends ~\$2.2B annually
- As this is not a permanent solution, these **costs do not include the inevitable transportation and disposal costs** to come in the future

How long does it take to deploy?

- Because the world has decades of experience, **interim storage can be deployed immediately**
- The actual placement of SNF into the dry casks depends on the inventory, and **can take months to years to complete**

What progress has been made to date?

- Temporary above-ground storage is the **only waste management solution for SNF currently being practiced worldwide**
- **No SNF globally has ever been moved from temporary storage to a permanent disposal site**

Why is this option so unpopular?

- **Cost** – billions of dollars are passed through to taxpayers each year for a solution that includes the inevitable bill for permanent disposal at some point in the future
- **Timing** – SNF is being stored above-ground decades longer than anticipated and, in most countries, with no permanent solution on the horizon
- **Safety** – risks include natural disasters, cask degradation, accidents, terrorist attacks, etc.

The Deep Isolation Approach

THE DEEP ISOLATION SOLUTION

Deep Isolation's mission is to provide the world's safest and most cost-effective solution for the permanent disposal of nuclear waste, becoming the dominant solution across the world

Our Solution

- Deep Isolation's solution places corrosion-resistant canisters containing waste in deep boreholes, greater than 1 kilometer below the surface – far deeper than is feasible with a mined repository
- Boreholes terminate in stable geological formations that have been out of contact with the biosphere for millions of years
- Key features of the solution include:
 - ✓ **Inexpensive Proven Drilling:** Remarkable advances in directional drilling technology have made such deep boreholes reliable and relatively inexpensive; leverages existing technology
 - ✓ **Permanent Isolation:** Our corrosion resistant canisters serve as an engineered barrier – and the billion metric tons of rock above them create the final impermeable barrier
 - ✓ **Time to Implement:** The technology and know-how exist and are ready to be deployed quickly
 - ✓ **Remote Handling:** Deep borehole emplacement does not require human involvement underground
 - ✓ **Minimal Transportation:** Disposal can take place at or near sites where nuclear waste is produced and currently stored, minimizing the cost and risk associated with waste transportation

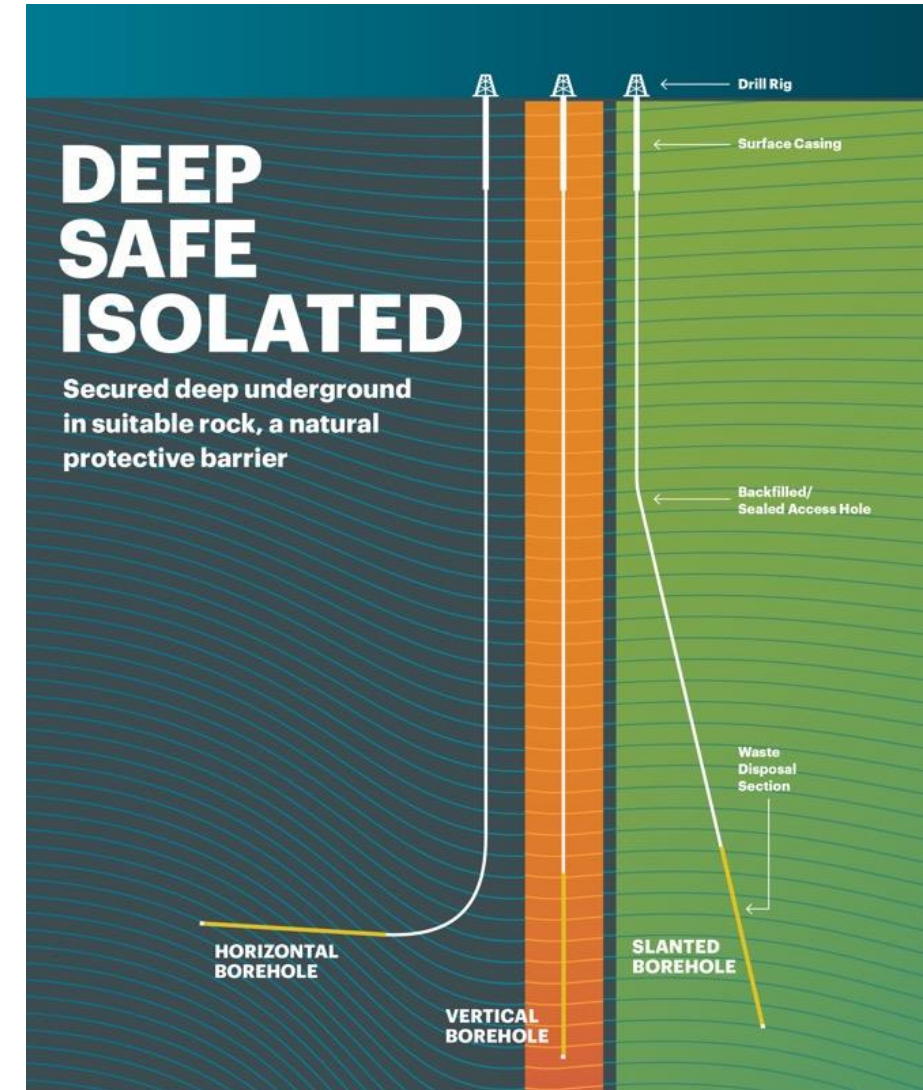

HOW DOES HORIZONTAL BOREHOLE DISPOSAL WORK?

Deep Isolation's repeatable process leverages proven technology and has been successfully tested and demonstrated

The disposal process consists of six stages:

- 1. Vertical Access:** Drill a vertical hole to a suitable depth and then gradually curve the direction until the drillhole is approximately horizontal. The horizontal section is the disposal region.
- 2. Casing Installation:** Line the drillhole with a carbon-steel pipe known as casing. Because the curved section is so gradual, the steel casing bends easily around it.
- 3. Canister Preparation:** Place the nuclear waste in corrosion-resistant canisters.
- 4. Canister Emplacement:** Lower canisters into the hole and push them into the disposal region. This process is completed using standard oil and gas industry practices.
- 5. Release:** Release canisters, withdraw the conveyance mechanism, and repeat.
- 6. Seal / Plug:** Seal the vertical hole with rock and bentonite clay after removing the casing, or use temporary plugs for interim storage.

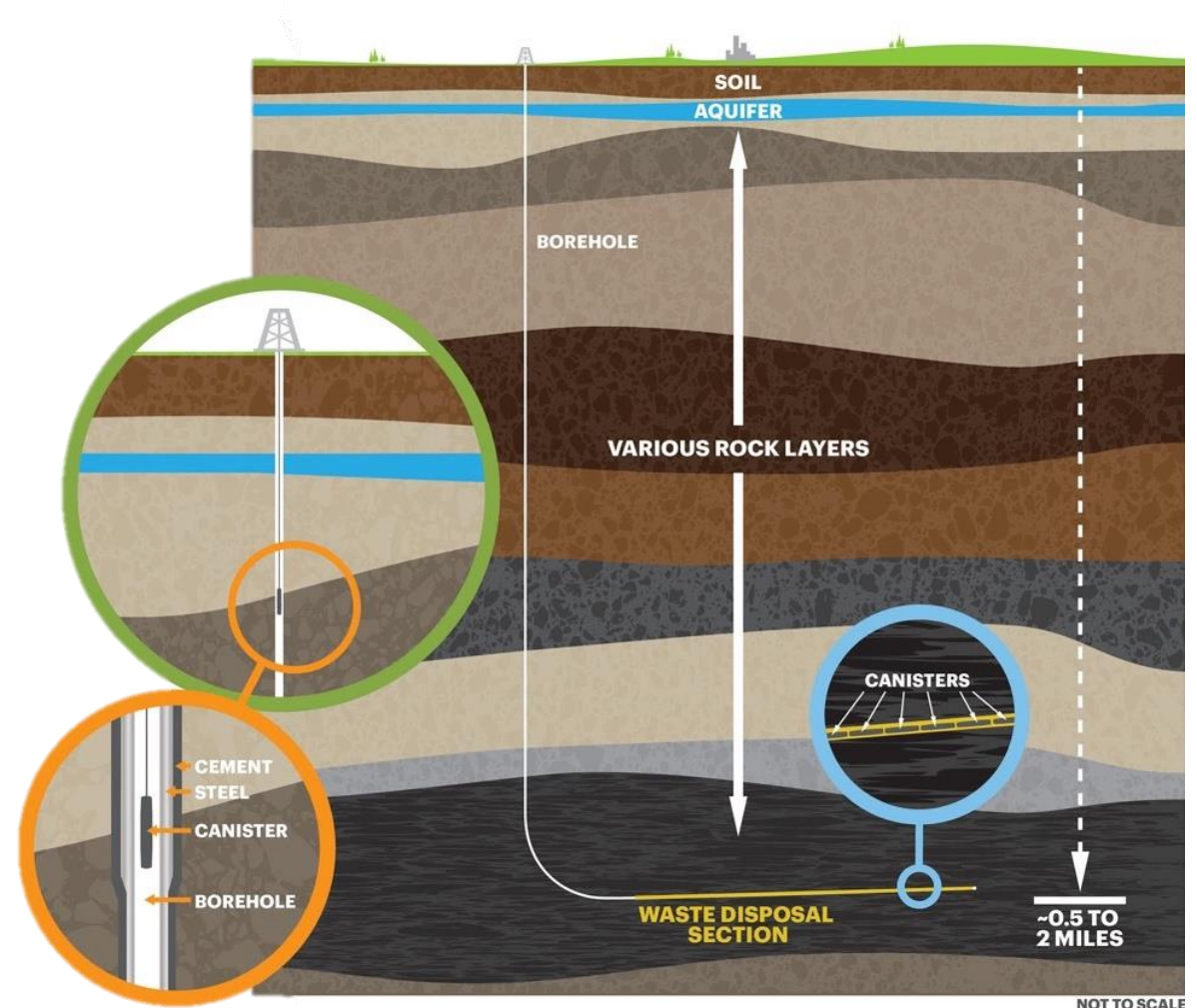

UNIVERSAL CANISTER SYSTEM (UCS)

- The UCS is a **Deep Isolation patented family of canisters** that:
 - i. Are engineered in a range of sizes (to accommodate a wide variety of advanced reactor waste forms) and thicknesses (to provide structural stability in a range of different disposal depths)
 - ii. Share common, standardized features, including closure designs and lifting attachments designed for interoperability with emplacement technologies used on a daily basis in the oil and gas industry
- Designed to **accommodate all major current and advanced nuclear waste streams**
- **Only triple-purpose canister system in the world** – integrates with (i) transport systems, (ii) interim dry cask storage and (iii) disposal (in deep boreholes or mined repositories)
 - Enables waste to be packaged once, avoiding costs and risks associated with future repackaging – even when a disposal path is uncertain
- Significant government support and investment from the U.S. and UK, with **\$7.1 million of government grant contracts to date**
- Preliminary safety evaluations were performed for design-limiting conditions to develop a canister design sufficient to **satisfy established and anticipated regulatory requirements**

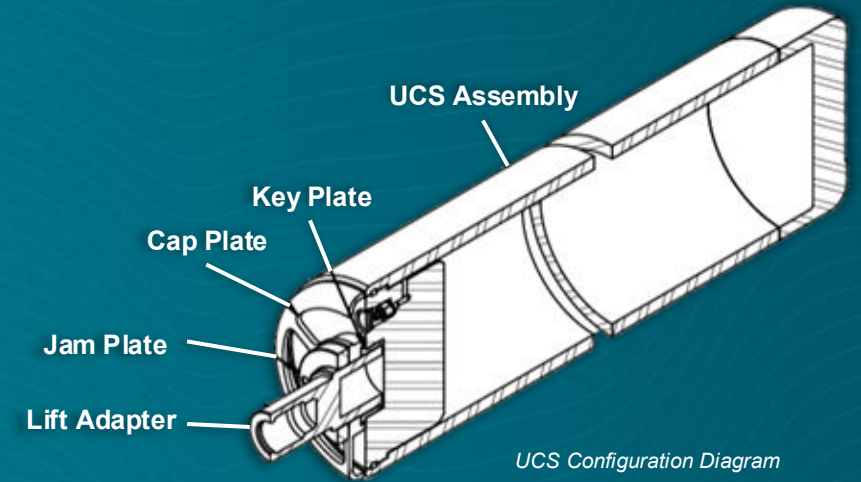

UCS Configuration Diagram



UCS prototype design, measuring about 16 feet in length and weighing over 4,000lbs (Nuclear AMRC, United Kingdom, circa 2024)

NUCLEAR WASTE MANAGEMENT COST ANALYSIS

Deep Isolation's borehole solution is far more economical than mined repositories or the current status quo – temporary storage before ultimate disposal

Disposal Cost Comparison (\$000s per MTHM)^(1,2)

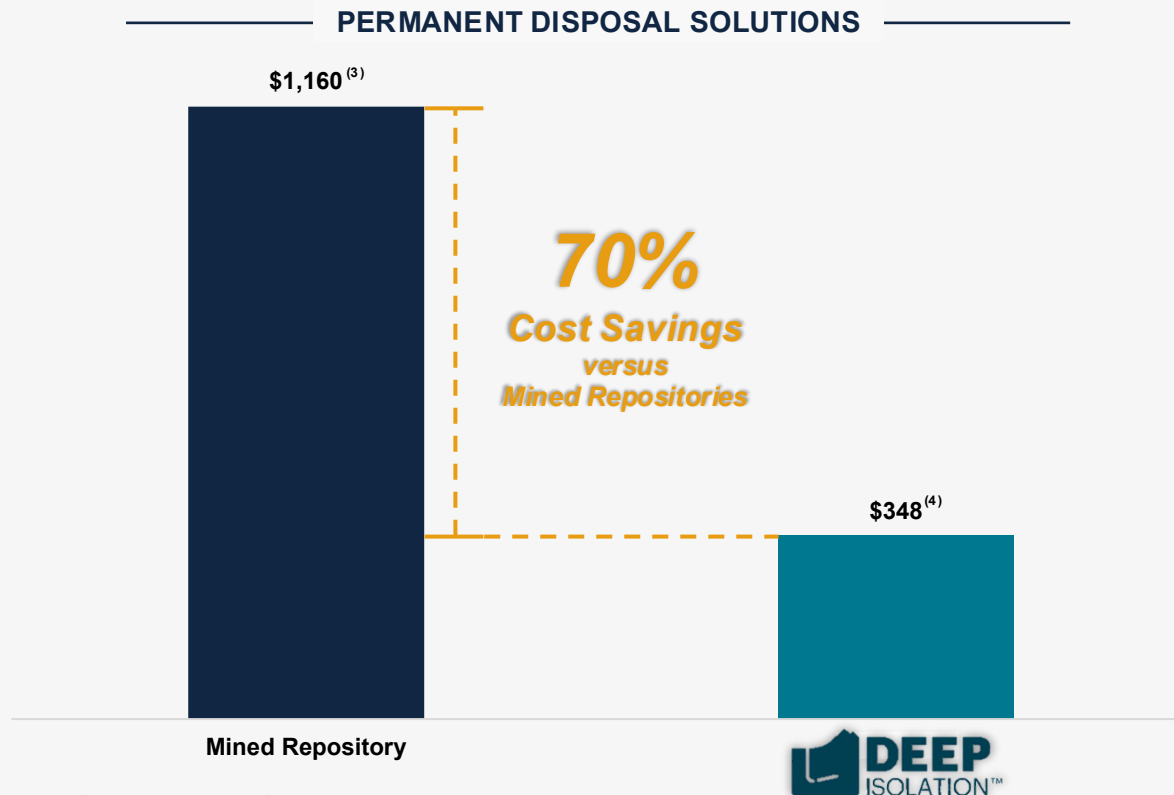

“KICK-THE-CAN” OPTION

- By Deep Isolation's estimates based on DOE data, the ongoing annual cost of storage is ~\$23k / MTHM / year
 - This means that Deep Isolation's deep borehole disposal solution is equivalent to ~20 years⁽⁵⁾ of temporary storage costs in the U.S.**
- Inevitably, the waste stored in these dry casks must ultimately be disposed of permanently in either mined repositories or deep boreholes
- When considering the combined costs of (i) permanent disposal canisters, (ii) waste repackaging, (iii) any necessary transportation and (iv) ultimate disposal, the status quo temporary storage option quickly becomes the most expensive and burdensome option

Sources: Amentum (published white paper); Deep Isolation Financial Model.

1) Does not incorporate costs of spent fuel transportation.

2) Values represented in real 2024 U.S. dollars.

3) Considers global average mined repository and does not include costs of spent fuel transportation.

4) Weighted average cost of disposal based on \$424k/MTHM and \$170k/MTHM for unprocessed and reprocessed waste, respectively, per the Deep Isolation Financial Model. Assumes 30% of global waste is reprocessed, while remaining 70% is unprocessed.

5) This assumes that U.S. spent nuclear fuel is disposed of at the Deep Isolation's average unit cost for direct disposal (\$424k/MTHM), with none reprocessed first as shown in the lower blended rate at Footnote (4).

EXTENSIVE PATENT PORTFOLIO & STRONG BARRIERS TO ENTRY

Deep Isolation has developed an expansive portfolio of IP, which has formed a wide competitive moat for any competitor who tries to enter the market with a similar solution while also creating significant licensing opportunities

IP Portfolio Overview

Large and growing IP portfolio of inventions, processes, designs and other specifications related to:

- ✓ Formation Suitability
- ✓ Repository Design
- ✓ Canister Design
- ✓ Emplacement
- ✓ Monitoring

- Deep Isolation is the only serious player in deep borehole disposal, and the competitive moat grows wider daily
- Deep Isolation patents cover multiple techniques for deep horizontal borehole disposal in many, if not most, countries dealing with the nuclear waste disposal issue
- Most patents support all borehole architectures, while some are specific to borehole shape (vertical, slant, or horizontal) and some are specific to storage formation geology
- Our UCS canister designs are patented and can be used for temporary storage as well

99⁽¹⁾
U.S. or International
Patents Issued

39⁽¹⁾
Patents in
Development

Licensing Opportunities

Collaboration through licensing agreements can help to facilitate the global adoption of the Deep Isolation disposal solution



Licensing options from reselling to delivery for commercial operators

- e.g., Licensing Partnership with  **amentum**
 - Premier global technical and engineering services leader
 - Strengthens collective positions in the global nuclear waste market
 - Initial targets for joint work include countries in Europe and the Pacific that represent a combined addressable market worth more than \$30 billion



Licensing options available when governments need to use their own local supply chain

(1) As of April 2026

WIDESPREAD SUPPORT FROM THE GLOBAL NUCLEAR COMMUNITY

Nuclear stakeholders across the globe have expressed formal support of Deep Isolation and our waste management solutions



“Kairos Power is excited to see the progress made by the Deep Isolation team in advancing the Universal Canister System and looks forward to continued collaboration. Together, Deep Isolation and Kairos Power are setting a precedent for innovation, safety, and sustainability in the safe and effective management of spent fuel from high temperature reactors.”



“Deep borehole disposal is an important alternative option for us to consider in Slovenia...[the study is] helpful in highlighting the potential benefits, the increasing maturity of, and required next steps for deep borehole disposal”



“Fermi Energia’s reference solution for spent fuel disposal... is provided by Deep Isolation. The solution includes packaging our SMR spent fuel in the Universal Canister System and then emplacing it in a deep borehole repository.”



“By joining forces with Deep Isolation, we’re not just addressing a critical need for effective nuclear waste management; we’re spearheading an era of innovation and responsibility in the nuclear industry.”



“[Deep Isolation’s study for ERDO] confirms ERDO’s own published assessment that deep borehole disposal could be a viable and cost-effective option for disposal... offering significant potential savings compared to conventional mined repositories.”



“Deep borehole disposal is a technology that offers huge potential benefits to Norway... so [we are] delighted to be working with Deep Isolation and the Deep Borehole Demonstration Center to demonstrate this technology here in Norway.”

Actively Engaged NGOs



The Nuclear Waste Disposal Market

OUR GLOBAL TOTAL ADDRESSABLE MARKET

The global market for nuclear waste disposal is almost entirely unclaimed, representing an opportunity for Deep Isolation to capture significant market share expected to be worth hundreds of billions of dollars over the coming decades

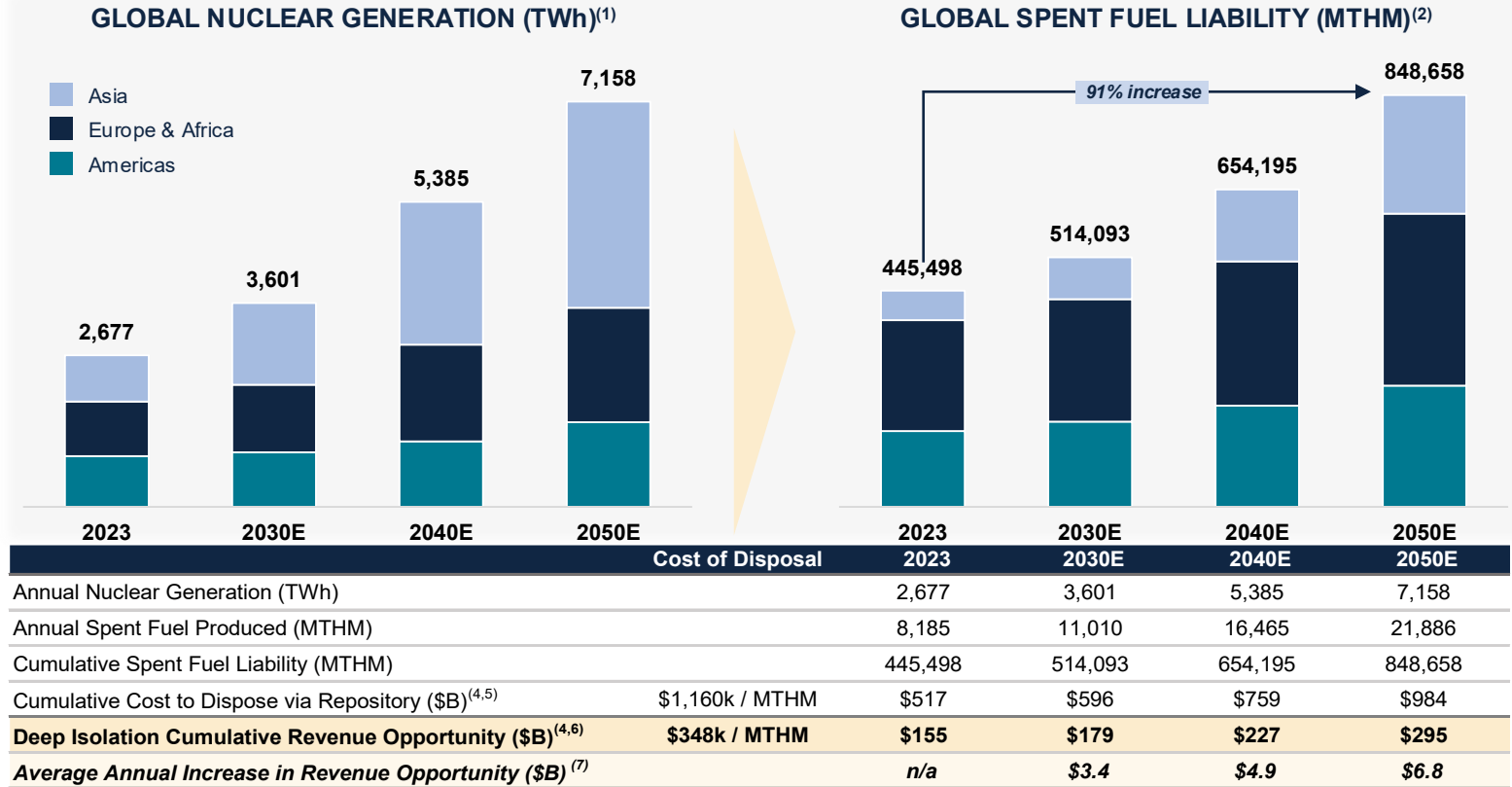

~\$1 Trillion
Cumulative Cost to Dispose via Mined Repositories by 2050^(3,4)

~\$295 Billion
Cumulative Addressable Market with Deep Isolation's Solutions by 2050^(3,4)











~70%
Global Cost Savings, Before Additional Transportation Savings

Sources: IAEA, EIA, U.S. DOE, World Nuclear Association, Amentum, Deep Isolation Financial Model

- 1) Based on IAEA's high case for annual global nuclear power generation.
- 2) Average MTHM generated per TWh of energy production is implied by historical U.S. commercial nuclear production and existing U.S. commercial spent fuel stockpiles. Includes existing inventory in both wet and dry storage, and does not separately incorporate cool-down timing in wet storage. Values displayed assuming no spent fuel has reached final disposal.
- 3) Does not incorporate costs of spent fuel transportation.
- 4) Cumulative values represented in real 2024 U.S. dollars.
- 5) Considers global average mined repository and does not include costs of spent fuel transportation.
- 6) Weighted average cost of disposal based on \$424k/MTHM and \$170k/MTHM for unprocessed and reprocessed waste, respectively, per the Deep Isolation Financial Model. Assumes 30% of global waste is reprocessed, while remaining 70% is unprocessed.
- 7) Represents annual increase in total addressable market between current and previous year highlighted in the table (e.g. \$3.4B average annual increase between 2023-2030).

COMPETITIVE LANDSCAPE

We do not have any true competitors for our DBD solution – in fact, many of our “competitors” are actually strategic partners

	INTERIM STORAGE	MINED REPOSITORY	DEEP BOREHOLE DISPOSAL	COMMENTARY
	✓	✓ ⁽¹⁾	✓	<ul style="list-style-type: none"> The world’s only company developing an end-to-end solution for deep borehole disposal Hybrid solution alongside mined repositories, under discussion with governments (e.g., ERDO, UK, others)
	✓	-	-	<ul style="list-style-type: none"> German-based dry cask manufacturer for interim nuclear waste storage Complementary capabilities with Deep Isolation – <i>does not manufacture disposal canisters</i>
	✓	-	-	<ul style="list-style-type: none"> Provides interim storage and transportation solutions
	✓	✓	-	<ul style="list-style-type: none"> Provides interim storage and transportation services Deep Isolation shareholder and supply chain partner; agreement to manufacture DI canisters <p>Both commissioned to provide Disposal Solutions for Yucca Mountain. Designs submitted to NRC but not implemented.</p>
	✓	✓	-	
	-	✓	-	<ul style="list-style-type: none"> Managed national waste programs in both the U.S. (WIPP) and UK; last contractor for Yucca Mountain Key supply chain and licensing partner for Deep Isolation
	-	✓	-	<ul style="list-style-type: none"> Currently manages and operates WIPP disposal repository Cooperation partner with DI since 2019; mentor-protégé agreement signed with DI for WIPP in 2023
	-	✓	-	<ul style="list-style-type: none"> Early-stage company looking to commercialize multinational mined repository solutions; in discussions about use of Deep Isolation’s solution
	-	✓	-	<ul style="list-style-type: none"> Finnish company managing mined repository program in Finland
	-	✓	-	<ul style="list-style-type: none"> Swedish company developing a mined repository in Sweden Sells consulting services for mined programs to other countries

1) Deep Isolation is in discussions to provide deep borehole disposal solutions alongside mined repositories. The company does not currently have commitments from potential customers to pursue hybrid solutions.

The Deep Isolation Business Model

DEEP ISOLATION PRODUCT LINES

We do not expect our customers to commit to implementation of the Deep Isolation solution in one single decision. Instead, we offer a ladder of engagement that builds confidence from the client while also generating early income for Deep Isolation

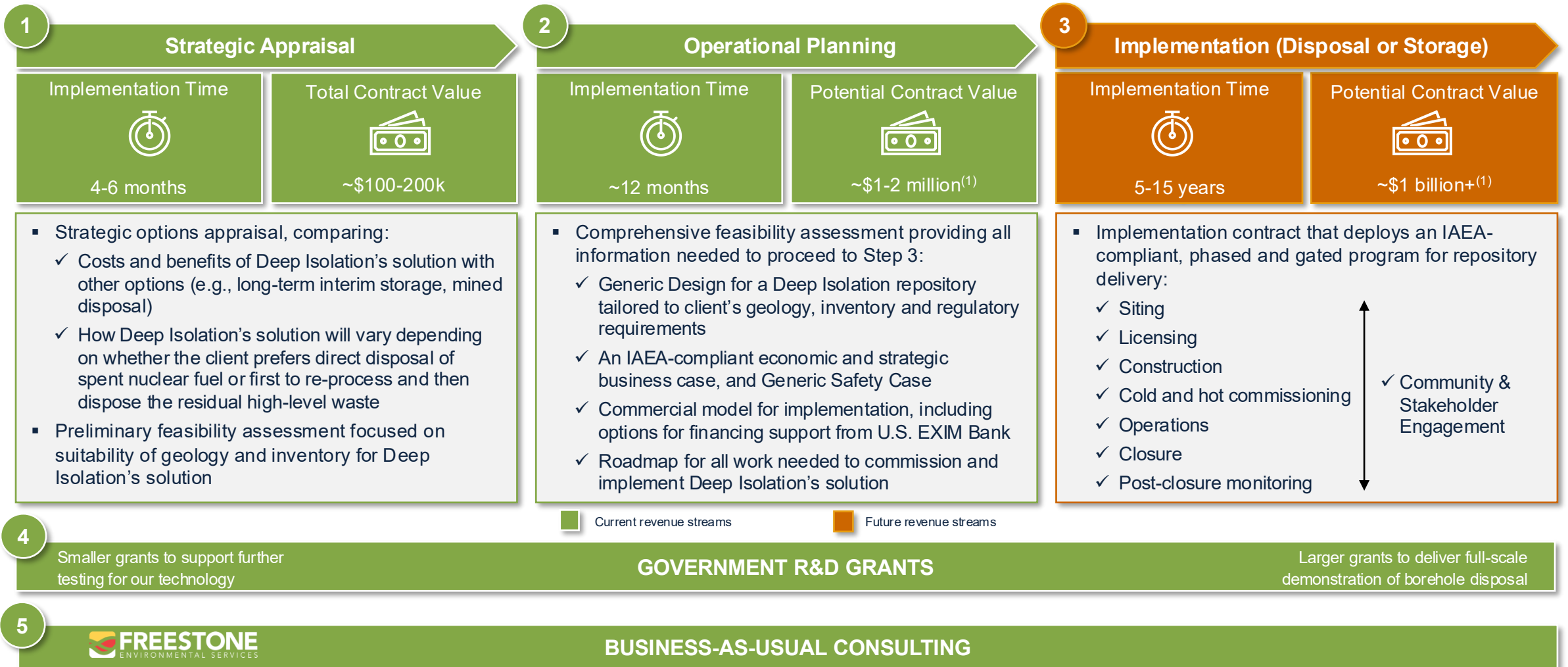

1) Based on Management’s assumptions and projections. For further detail, see the Company’s Form 8-K filed with the SEC on July 28, 2025.

Acquired in 2021, Freestone offers key synergies with our core disposal solution and provides cash flow to the business

Freestone Overview

- Freestone Environmental Services, Inc. (“Freestone”) is a multi-discipline environmental and water resources consulting firm serving federal, state, municipal and private clients
- Team of 32 part- and full-time employees with decades of professional consulting experience in solving technical and regulatory challenges
- Variety of technical backgrounds to support a range of environmental services to environmental cleanup sites and the U.S. Government
- Freestone also performs R&D work that has led to the development of its automatic hexavalent chromium sensor
- Headquartered in Richland, Washington

Synergies for Deep Isolation

- ✓ **Expands bench strength and provides additional human capital, including:**
 - ✓ Access to professional geologists
 - ✓ Support for drilling plans
 - ✓ Dedicated procurement team
 - ✓ Hazardous waste permit expertise
 - ✓ GIS expertise
 - ✓ Site characterization support
 - ✓ Validation of lab results

- ✓ **Existing subcontractor with U.S. DOE’s prime contractors**

- ✓ **Access to Freestone’s catalog of back office resources**

- ✓ **Strategically and culturally aligned**

FREESTONE’S SERVICES



REGULATORY SUPPORT

Assist private and government clientele in solving regulatory related issues associated with the evolving local, state, and federal environmental requirements



INVESTIGATION & REMEDIATION

Perform environmental investigations to characterize conditions of a site, and determine if hazardous substances are present to the degree that remediation or cleanup may be necessary



ENVIRONMENTAL DATA REVIEW & MANAGEMENT

Provide data verification and quality reviews for federal environmental cleanup actions, using spatial analysis and statistical evaluation to determine environmental impacts and assess progress



TECHNOLOGY DEVELOPMENT

Developed a cable-deployed hexavalent chromium sensor for wells or water bodies. The sensors serve as an alternative to manual sampling and analysis, offering continuous data collection and reduced cost per measurement

DEEP ISOLATION IS ENGAGED IN ALL MARKETS WITH COMMERCIALIZATION POTENTIAL GLOBALLY (1)

Deep Isolation manages prospective clients through four phases of engagement, each with specific actions and stage-gates

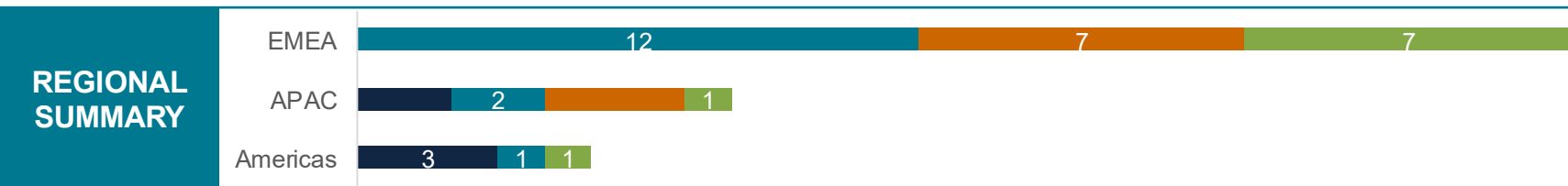

1) Countries with commercialization potential excludes six countries with current or planned nuclear that are not being considered at this time for geopolitical reasons (China, Iran, Israel, Kazakhstan, Pakistan and Russia), as well as France and Sweden, who have both been disqualified as potential clients due to their commitment to geological mined repository solutions.

OUR CLIENTS HELP FUND OUR BUSINESS DEVELOPMENT

Our awards & contracts have led to advances in deep borehole disposal technology, follow-on work and new opportunities

COUNTER-PARTY	PARTNERS	COUNTRY	KEY FINDINGS / ACHIEVEMENTS	NEXT STEPS
			<p>Several awards granted, totaling over \$6 million – expanding the capabilities of deep borehole disposal to small modular reactors, advanced reactors, and reprocessed fuels – and expand Deep Isolation’s solution from disposal to address storage and transportation as well</p>	 <p>Current pipeline of DOE projects in our sales pipeline is > \$100 million. Secretary Wright has publicly named Deep Isolation as one of ARPA-E’s foremost innovators</p>
	N/A		<p>Deep boreholes offer potentially significant savings and flexibility compared to geologic disposal facilities for the UK’s high-heat generating radioactive waste</p>	 <p>The UK Government has invested in a UK supply chain for our canister. Amentum has negotiated an exclusive license to market our technology for use in the UK’s £38 million disposal program.</p>
	N/A		<p>“Deep borehole disposal is an important alternative option for us to consider in Slovenia...[the study is] helpful in highlighting the potential benefits, the increasing maturity of, and required next steps for deep borehole disposal” – Leon Kegel, Head of Planning and Development at ARAO</p>	 <p>Initial study led to two follow-on pieces of work. Currently in discussion on UCS deployment at Krsko NPP, and long-term disposal</p>
			<p>“It confirms our view that borehole disposal offers a suitable and cost-competitive alternative for spent nuclear fuel, high-level radioactive waste and long-lived low- and intermediate-level radioactive waste for the ERDO countries” – Håvard Kristiansen, Sr. Advisor R&D at NND</p>	 <p>ERDO have become founding members of Deep Borehole Demonstration Center. Follow on projects with Croatia and Slovenia already delivered, more in the pipeline.</p>
			<p>Deep Isolation boreholes could be a safe and flexible option for all regions in Estonia, with the northern coastal areas providing the most suitable locations</p>	 <p>Fermi Energia has adopted Deep Isolation as its disposal solution. The Estonian Government has now also become a client, working with us via State Dept’s FIRST program</p>
			<p>With support from US Trade and Development Agency, Deep Isolation is undertaking a Feasibility Study into deployment of its technology to dispose Bulgaria’s inventory of spent nuclear fuel, from Soviet-era legacy reactors, new Westinghouse AP 1000s, and potential future SMRs.</p>	 <p>Feasibility Study concludes at end 2026, and will include a Commercial Model and Delivery Plan for siting, licensing, construction, operation and eventual closure of a deep borehole repository.</p>

DEEP BOREHOLE DEMONSTRATION CENTER

An independent, nonprofit, science-driven organization funded on a multinational, public-private-partnership basis

Inception and Overview

- In 2021-2022, Deep Isolation (in partnership with The University of Sheffield) conducted an in-depth survey of international stakeholder views from the regulatory, policy and waste management communities
 - Sponsored by UK Department for Business, Energy & Industrial Strategy and published at multiple international waste management conferences
- Study found that 4 out of 5 participants would welcome greater international collaboration on deep borehole disposal
 - Key themes in progressing the DBD solution included (i) demonstration and (ii) guidance
- The Deep Borehole Demonstration Center was founded in direct response to that demand, with the aim of advancing the maturity of the safety case for DBD and the technical readiness levels of the disposal concept

Key Events

- **February 2023:** Initial emplacement and retrieval demonstration of a full weight and size disposal canister in Cameron, TX is successful
- **May 2023:** Deep Borehole Demonstration Center signs MOU with Norsk Kjernekraft to collaborate on a demonstration of DBD in Norway
- **November 2023:** Deep Borehole Demonstration Center signs MOU with TNO to collaborate on a demonstration of DBD in the Netherlands
- **August 2024:** Deep Isolation's first fully prototypic disposal canister arrives at the Center for testing in prototypical pressure and temperature conditions, at start of test program supported by grants from UK and U.S. governments
- **September 2024:** Deep Borehole Demonstration Center hires Andy Griffith, a 40-year veteran of the nuclear energy sector with experience in the U.S. Navy, DOE and Battelle, as its new Executive Director
- **January 2026:** Groundbreaking held at Deep Borehole Demonstration Center facility in Cameron, TX for multi-year, full-scale, at-depth deep borehole demonstration program

DEEP BOREHOLE DEMONSTRATION CENTER

The Deep Borehole Demonstration Center has been actively testing Deep Isolation's technology in Texas since January 2023



Initial full-scale PWR canister test on 23 February 2023

Study tour to DBDC by Czech Government, Dec 2024



Class 1 UCS prototype, at Deep Isolation's fabricator (RV Industries in Philadelphia), prior to shipping to DBDC for testing



Corrosion testing at pressures and fluid chemistry of disposal depths, at Halliburton facility in Carrollton, TX

DEMONSTRATION PROJECT GROUNDBREAKING

Inaugural demonstration project launched by Deep Isolation at the DBDC demonstration site located at Halliburton's Drilling Technology Facility near Cameron, TX

Multi-Year Full-Scale Demonstration Program Groundbreaking

- Held January 28, 2026 at the Deep Borehole Demonstration Center's demonstration site located at the Halliburton Drilling Technology Facility near Cameron, TX
- The groundbreaking event officially launched Deep Isolation's full-scale demonstration program to conduct testing of deep borehole technology for safely and permanently disposing of nuclear waste
- Project collaborators, including Halliburton, the DBDC, Amentum, NAC International, and Occlusion Nuclear Solutions, participated in the event
- The demonstration program, which does not utilize radioactive material, will provide crucial data and operational experience to further the commercialization strategy for Deep Isolation's deep borehole disposal technology



COLLABORATIONS / GLOBAL SUPPLY CHAIN

Deep Isolation’s strong collaborator network enhances capabilities and reach

PARTNER	DESCRIPTION
	<ul style="list-style-type: none"> Deep Isolation has signed a Memorandum of Agreement with technical and engineering services provider Amentum to cooperate on the commercialization of Deep Isolation’s radioactive waste disposal technology around the world.
	<ul style="list-style-type: none"> Deep Isolation has a Mentor-Protégé Agreement with SIMCO, a Bechtel subsidiary, which allows SIMCO to mentor Deep Isolation while providing scopes of work at the Waste Isolation Pilot Plant – the world’s only operational deep geological repository.
	<ul style="list-style-type: none"> Deep Isolation and Dominion Engineering, Inc. cooperate in the sales, development, and deployment of Deep Isolation’s patented SNF and HLW disposal technology.
	<ul style="list-style-type: none"> Deep Isolation signed a long-term cooperation and licensing agreement with NAC International to design, manufacture and supply the canisters that will be used to safely store and/or dispose of nuclear waste in deep horizontal boreholes.
	<ul style="list-style-type: none"> Deep Isolation and Navarro have entered into a strategic partnership to jointly demonstrate the feasibility of Deep Isolation’s solutions for disposal of high-level nuclear waste in the U.S. and abroad.
	<ul style="list-style-type: none"> Deep Isolation is collaborating with Halliburton on the deployment of its deep borehole nuclear waste disposal solution, with Halliburton providing drilling, well construction, and subsurface project management expertise – including construction of a full-scale, at-depth repository for non-radioactive demonstration at the Halliburton Drilling Technology Facility near Cameron, Texas
	<ul style="list-style-type: none"> Nuclear AMRC completed the manufacturing of the first full-size prototype canister in conjunction with Deep Isolation and NAC.
	<ul style="list-style-type: none"> Deep Isolation’s subsurface partner, Occlusion Nuclear Solutions brings advanced drilling, wellbore integrity, and real-time monitoring expertise to support safe and precise emplacement and retrieval of waste canisters. Integrating oil and gas engineering best practices with nuclear-grade safety and digital tracking, OCNS enhances the operational strength of Deep Isolation’s deep borehole disposal solution.

PROACTIVE SUPPORT FROM THE U.S. GOVERNMENT

Deep Isolation has garnered significant support from the U.S. Government from multiple federal agencies through direct contracts and formal Advocacy for Deep Isolation’s solutions internationally

Team USA



INTERNATIONAL
TRADE
ADMINISTRATION



- The Advocacy Center of the U.S. International Trade Administration (“ITA”) has identified Deep Isolation as a unique part of the U.S. offer in nuclear export markets, suitable for formal Advocacy by the Federal Government to overseas governments
- Initial Advocacy status has already been granted in the Philippines. ITA is now encouraging Deep Isolation to submit further advocacy applications in Europe, the Middle East and Asia.
- U.S. Department of State’s FIRST program has appointed Deep Isolation as its Spent Fuel and Waste Management Consultancy provider in Central and Eastern Europe
- Deep Isolation is supporting FIRST as an expert advisor on spent fuel and waste management for new-to-nuclear countries looking to deploy SMRs



Study tour to DBDC by Czech Government, December 2024, funded by State Dept FIRST program

Co-investment in R&D



- Department of Energy is investing over **\$6 million** in Deep Isolation technology through ARPA-E and Small Business Innovation Research contracts - supporting collaboration with Argonne National Lab, Berkeley National Lab, Idaho National Lab, and companies including Kairos Power and Oklo



Secretary of Energy Wright with Deep Isolation Team at ARPA-E Summit, March 2025

Financial support from USTDA and ExIm



- In December 2024, the U.S. Trade and Development Agency announced grant support of \$1.2 million for Deep Isolation Feasibility Study in Bulgaria:
 - ✓ A delivery plan with supporting commercial model for siting, design, licensing, construction & operation of a deep borehole repository for: existing waste at Kozloduy NPP, new waste from two AP-1000s and future SMR waste
 - ✓ In positive dialogue with U.S. Export-Import Bank to provide 22-year financing to support capital expenditure by Bulgarian government (and other governments) on Deep Isolation technology



Enoh Ebong (Director of USTDA) and Sergey Tzochev (Head of the Board of Directors for State Enterprise Radioactive Waste) signing Deep Isolation Grant Agreement on December 13, 2024



DEEP
ISOLATION®

Thank You
